

REQUIREMENTS LIST FOR WORKSHOP

A LITTLE BIT OF THIS & A LITTLE BIT OF THAT

ONE DAY CLASS WITH LEE CLELAND

Lee Cleland © 2007

Quilting Experience Level Required: Intermediate Quilter Onward.

No Basic free-motion quilting instruction will be given in this class.

KIT COST: \$20

Fabric: (Min. 40" wide)

1 1/2yds of light plain coloured fabric – for ease of drawing designs

One 20" x 40" rectangle of thin batting

A variety of markers for marking designs onto your fabric plus

Lead pencil and permanent fine Sharpie (Texta)

Walking foot & free-motion foot for sewing machine

Fine thread to match or contrast with your fabric, depending on your sewing machine skills

Pre-wind a couple of bobbins

Machine needles – Sizes 70 or 80: Sharps or Quilting or Jeans/denim

Scissors, qic-un-pic, straight pins etc.

Extra safety pins – aerosol sprays do not travel by plane.

MARK & BASTE YOUR QUILT BEFORE LEAVING HOME - PLEASE !

Cut fabric into two 20" x 40" rectangles, the amount left over is for binding the quilt.

Draw up the top piece of fabric following the directions below & see diagram pg.2:

Mark an 18" x 39" rectangle on one piece of fabric

Working from the left hand side – draw vertical lines at 4 1/2 "and 9"

Divide this area into eight 4 1/2 squares, and draw 1/2" diagonal grid over this area.

Draw vertical lines 9", 18" and 21" from this grid work

Divide the two 9" strips into four 9" squares and then diagonally as in diagram.

Leave the 3" strip as it is.

Now working from the right hand side – mark the half way point of the side and draw diagonals from this point to the last line of the 3" strip where it touches the quilt edge.

Then divide these two lines in half to the corners.

Baste your quilt layers together in your preferred method leaving the five triangles to the right of the 3" strip unbasted, and using a walking foot quilt all the lines in the basted area. Quilt only 6 of the 8 squares of diagonal grid (that is leaving 2 squares with the grid unquilted) and bring with you to class.

A LITTLE BIT OF THIS AND A LITTLE BIT OF THAT

QUILT DIAGRAM
Lee Cleland © 2007

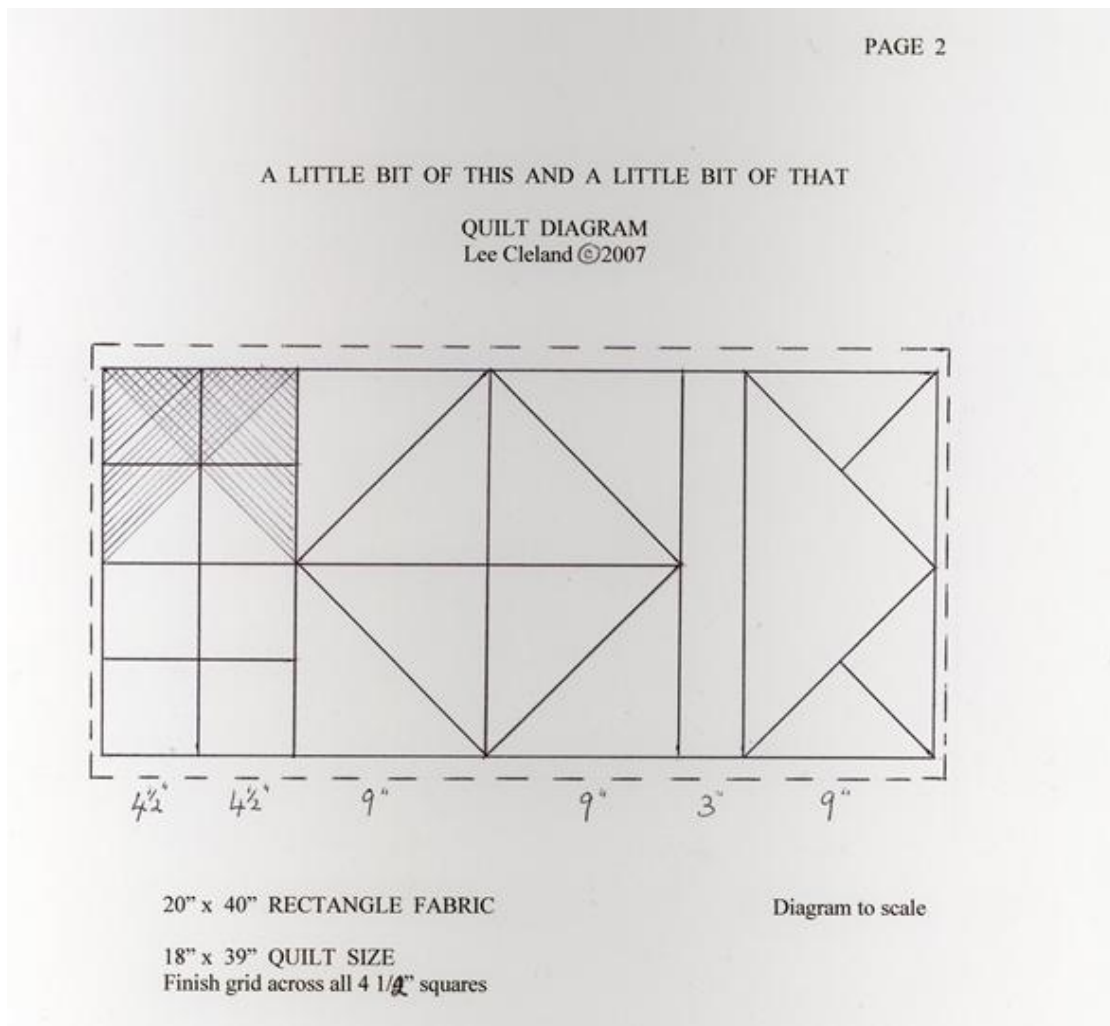

20" x 40" RECTANGLE FABRIC

Diagram to scale

18" x 39" QUILT SIZE
Finish grid across all 4 1/2" squares